

DETALHE DIMENSÕES DE SUPORTES E ENCAIXAMENTOS

DIAM. (mm)	SUporte	Distância	Distância	Distância
40	1"	1"	1"	1"
50	1 1/2"	1 1/2"	1 1/2"	1 1/2"
63	2"	2"	2"	2"
75	2 1/2"	2 1/2"	2 1/2"	2 1/2"
90	3"	3"	3"	3"
100	3 1/2"	3 1/2"	3 1/2"	3 1/2"
125	4"	4"	4"	4"
150	5"	5"	5"	5"

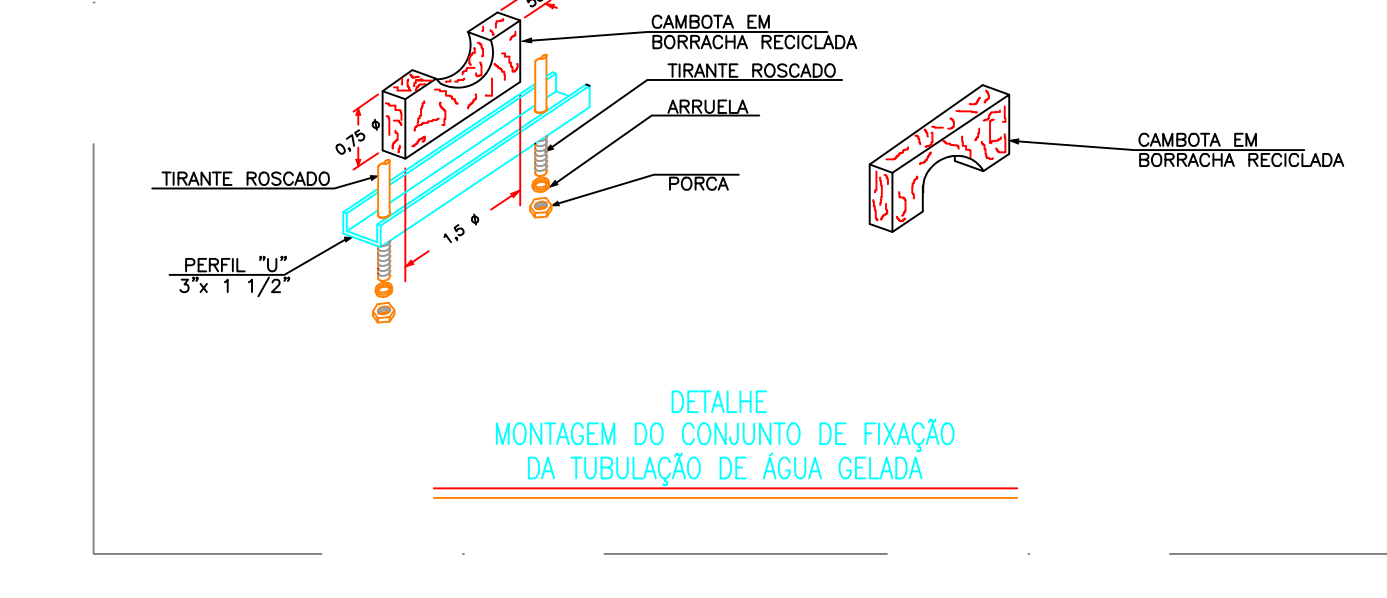
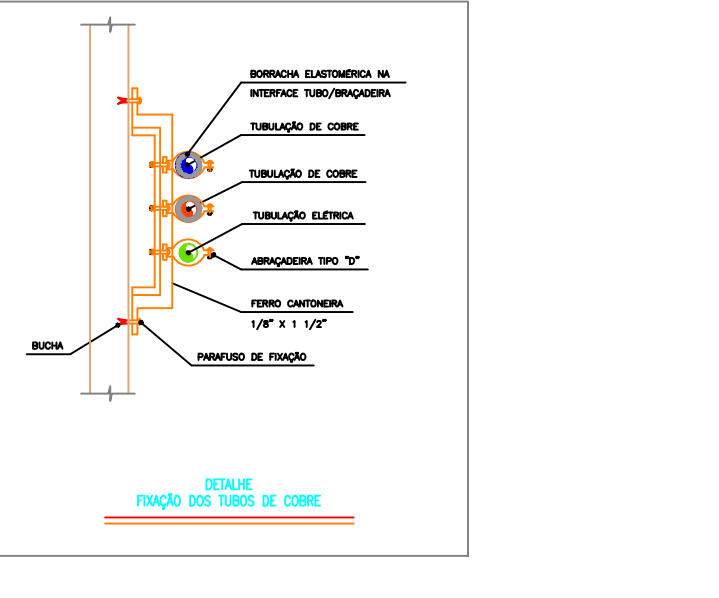
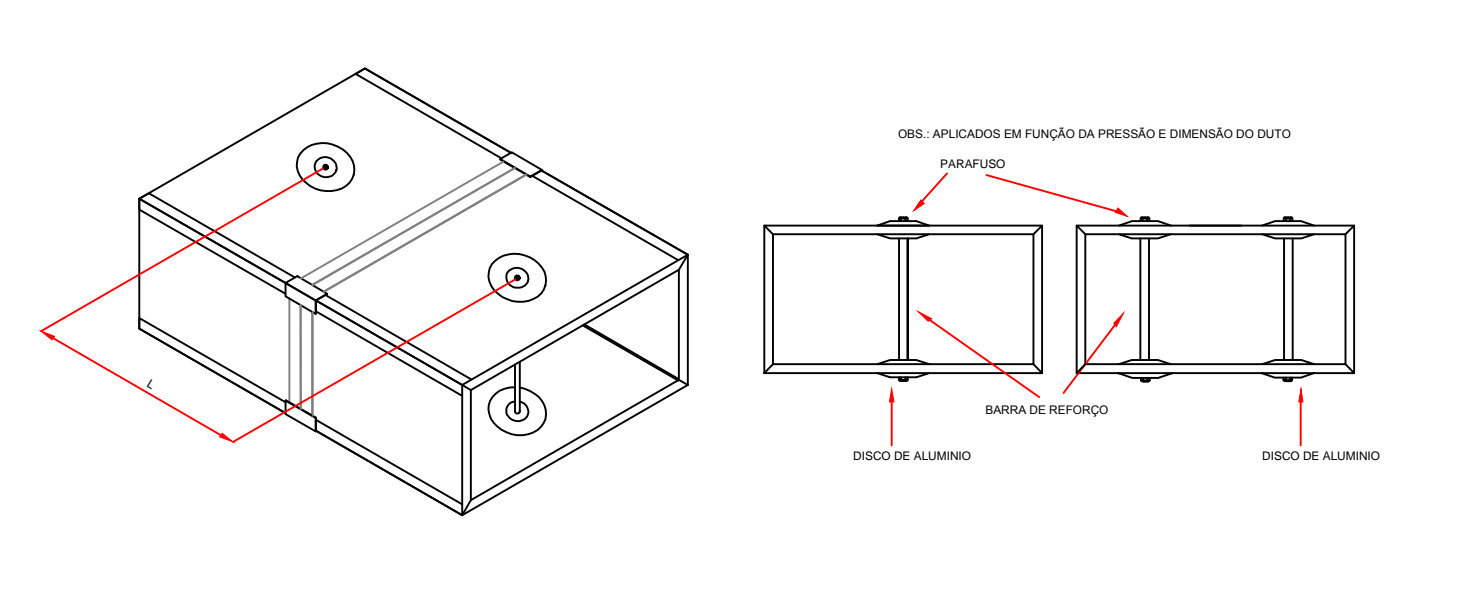
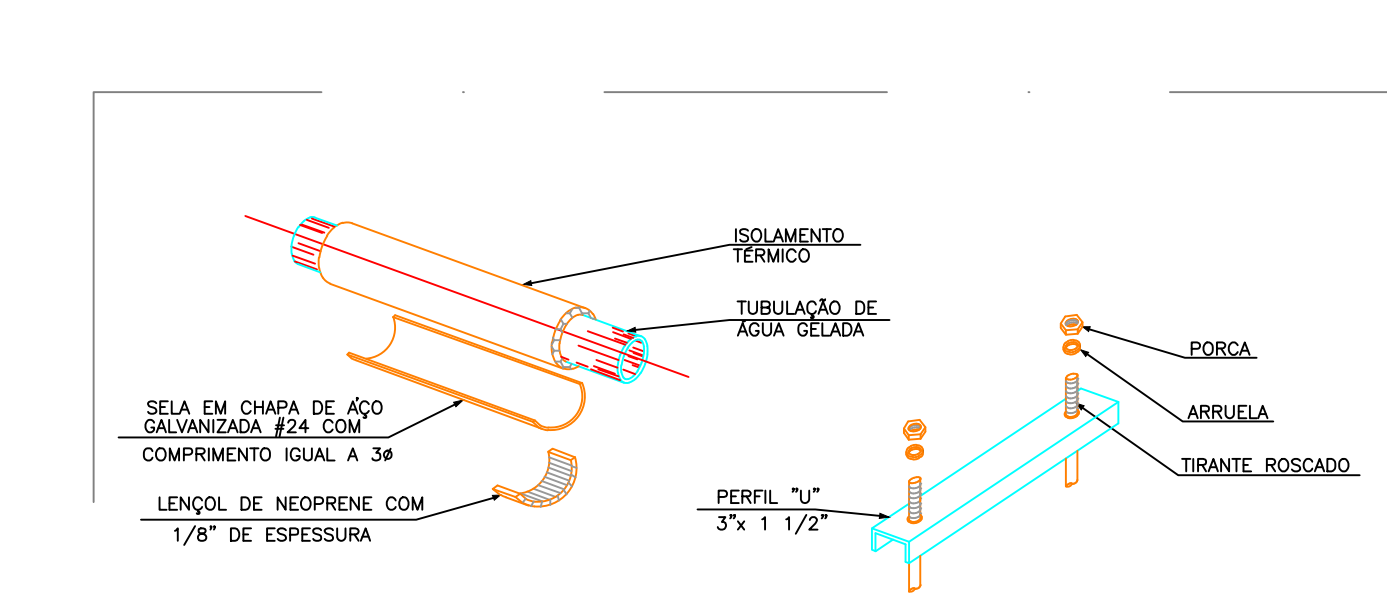
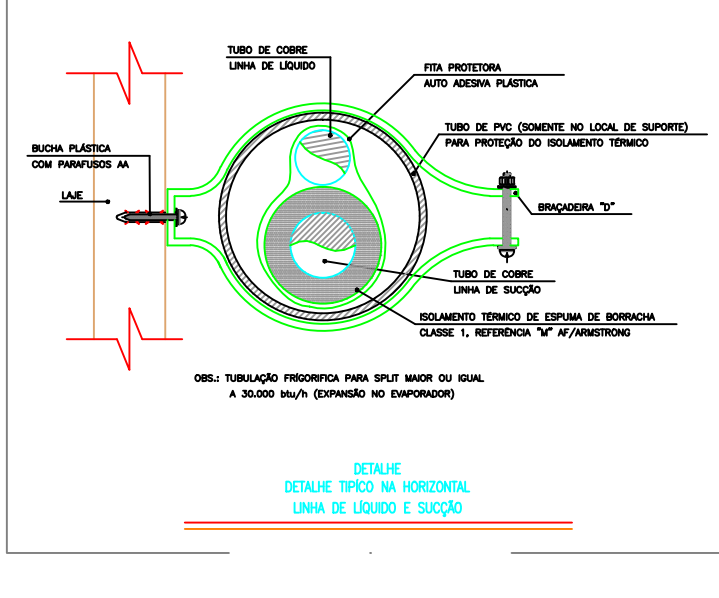
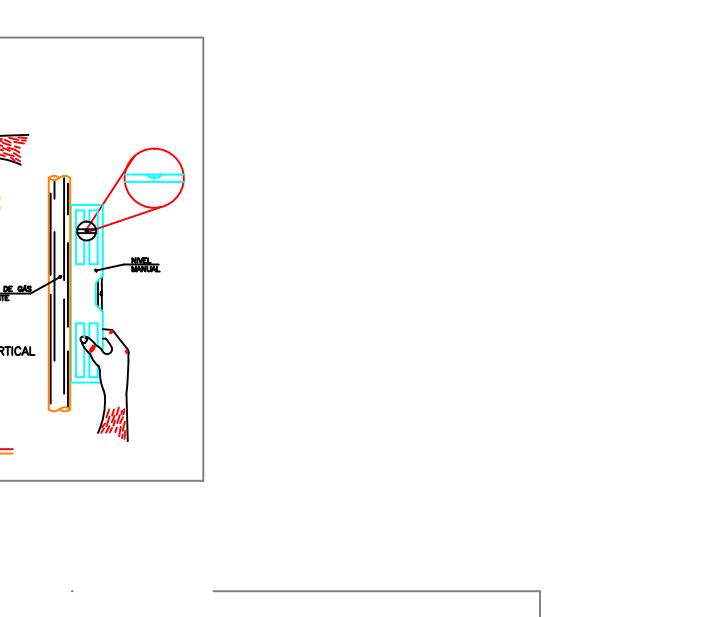
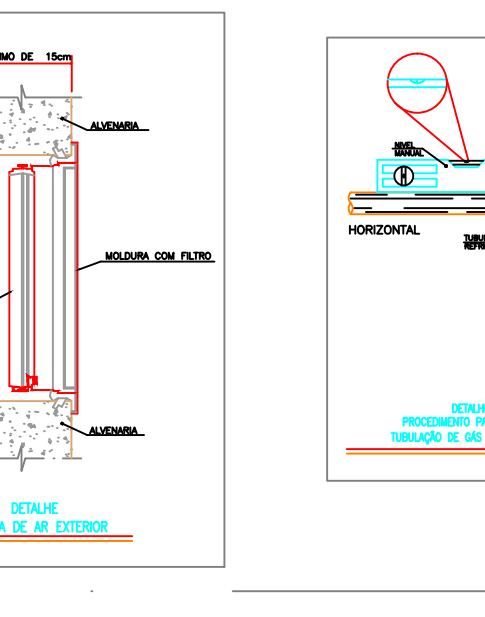
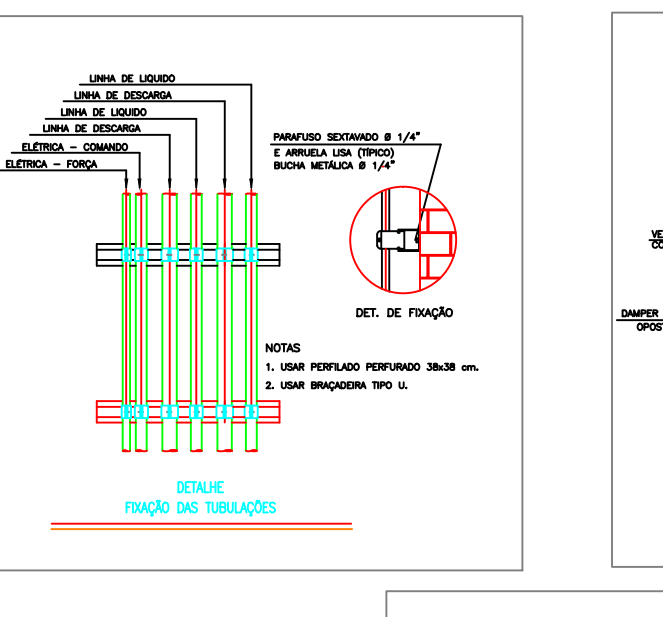
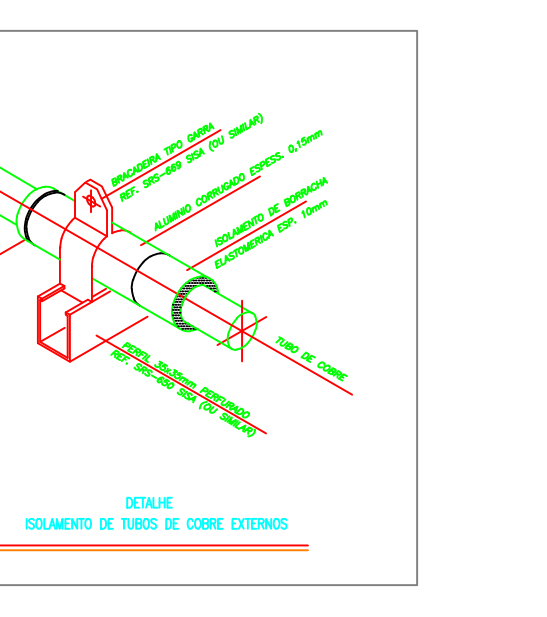
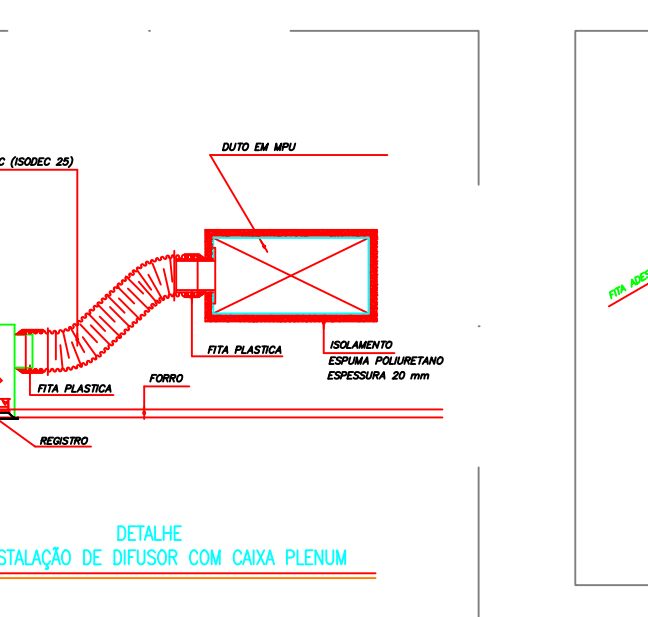
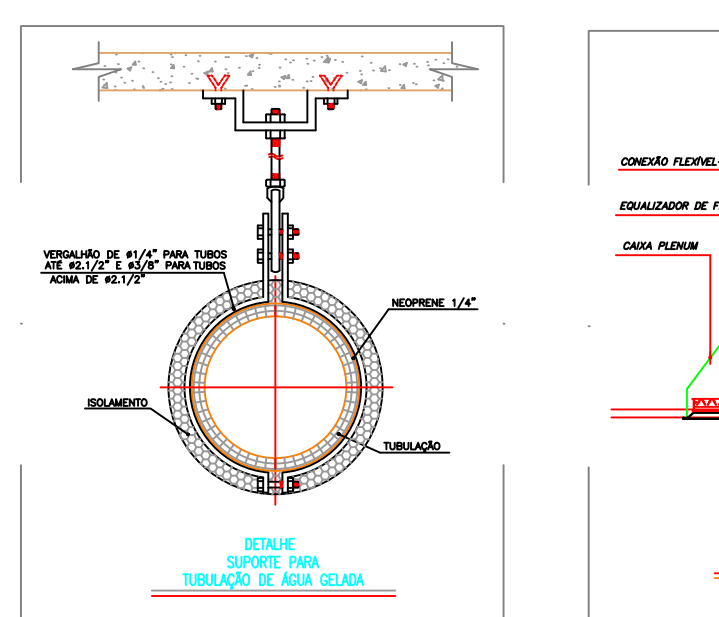
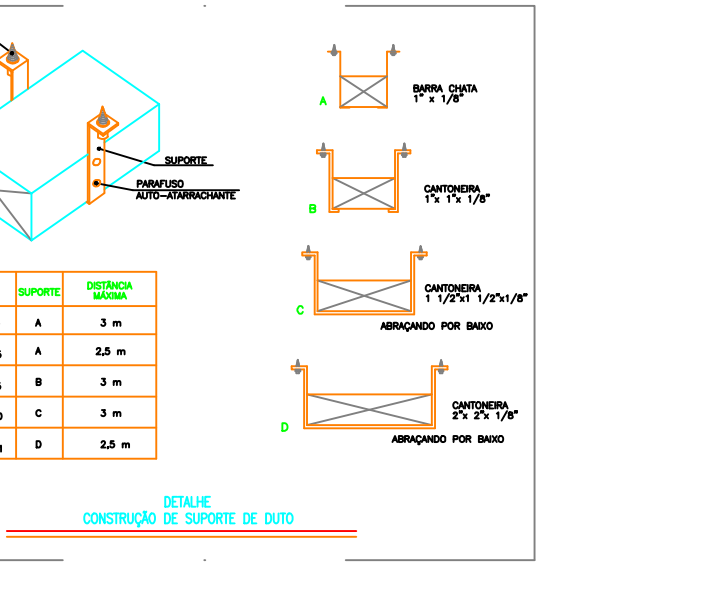
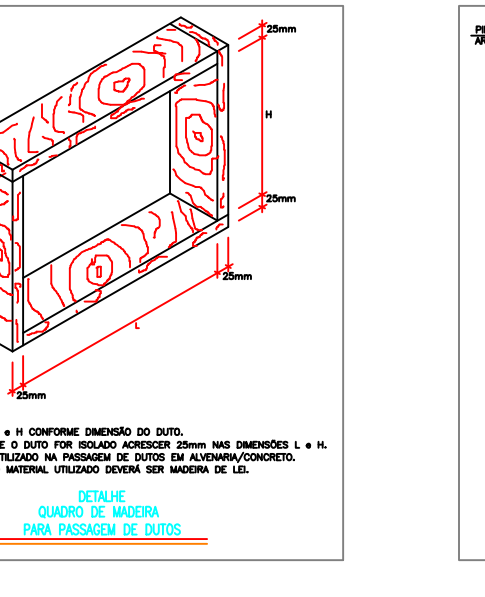
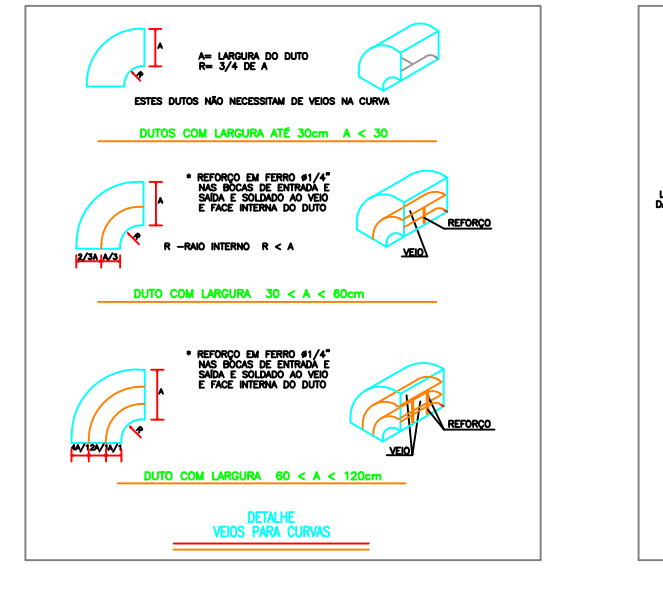

DETALHE REFORÇO INTERNO

Pressão (mmHg)	10	15	20	25	30	40	50	60	70	80	90	100
Distância entre rebordos "L" (mm)	1,4	1,1	0,9	0,8	0,7	0,6	0,5	0,5	0,4	0,4	0,4	0,4
Módulo do duto (mm)	150	175	200	225	250	300	350	400	450	500	550	600
150	1	1	1	1	1	1	1	1	1	1	1	1
175	1	1	1	1	1	1	1	1	1	1	1	1
200	1	1	1	1	1	1	1	1	1	1	1	1
225	1	1	1	1	1	1	1	1	1	1	1	1
250	1	1	1	1	1	1	1	1	1	1	1	1
300	1	1	1	1	1	1	1	1	1	1	1	1
350	1	1	1	1	1	1	1	1	1	1	1	1
400	1	1	1	1	1	1	1	1	1	1	1	1
450	1	1	1	1	1	1	1	1	1	1	1	1
500	1	1	1	1	1	1	1	1	1	1	1	1
550	1	1	1	1	1	1	1	1	1	1	1	1
600	1	1	1	1	1	1	1	1	1	1	1	1
650	1	1	1	1	1	1	1	1	1	1	1	1
700	1	1	1	1	1	1	1	1	1	1	1	1
750	1	1	1	1	1	1	1	1	1	1	1	1
800	1	1	1	1	1	1	1	1	1	1	1	1
850	1	1	1	1	1	1	1	1	1	1	1	1
900	1	1	1	1	1	1	1	1	1	1	1	1
950	1	1	1	1	1	1	1	1	1	1	1	1
1000	1	1	1	1	1	1	1	1	1	1	1	1
1050	1	1	1	1	1	1	1	1	1	1	1	1
1100	1	1	1	1	1	1	1	1	1	1	1	1
1150	1	1	1	1	1	1	1	1	1	1	1	1
1200	1	1	1	1	1	1	1	1	1	1	1	1
1250	1	1	1	1	1	1	1	1	1	1	1	1
1300	1	1	1	1	1	1	1	1	1	1	1	1
1350	1	1	1	1	1	1	1	1	1	1	1	1
1400	1	1	1	1	1	1	1	1	1	1	1	1
1450	1	1	1	1	1	1	1	1	1	1	1	1
1500	1	1	1	1	1	1	1	1	1	1	1	1
1550	1	1	1	1	1	1	1	1	1	1	1	1
1600	1	1	1	1	1	1	1	1	1	1	1	1
1650	1	1	1	1	1	1	1	1	1	1	1	1
1700	1	1	1	1	1	1	1	1	1	1	1	1
1750	1	1	1	1	1	1	1	1	1	1	1	1
1800	1	1	1	1	1	1	1	1	1	1	1	1
1850	1	1	1	1	1	1	1	1	1	1	1	1
1900	1	1	1	1	1	1	1	1	1	1	1	1
1950	1	1	1	1	1	1	1	1	1	1	1	1
2000	1	1	1	1	1	1	1	1	1	1	1	1

